

# 225 Series Electrical Actuator

+1-413-233-1888

[www.governors-america.com](http://www.governors-america.com)

## 1 INTRODUCTION

The 225 Series electric actuator is a rotary output, linear torque, proportional servo that is typically used as an engine fuel control positioning device. The 225 combines fast operation, multi voltage usage, wider rotation angles, and proven reliability.

This easy to install and maintain actuator is proven to outlive the life of the engine, and require virtually no maintenance once installed.

- Internal Return Spring with optional rates
- 2.2 lb. ft. Torque
- 25° Rotation with ADC225GAS offering greater travel
- Rapid Response to Transients
- Multiple Mounting Positions
- Universal Design
- High Temperature coil is available (ADC225KS)

A universal solution to fuel injected pumps, with or without mechanical governors, rotary type pumps, and medium sized gaseous fueled engines. The 225 is a great alternative to the 176 series.



## 2 SPECIFICATIONS

PERFORMANCE		
Available Torque (w/o Return Spring)		2.2 ft-lb MAX [2.7 N·m]
Maximum Operating Shaft Travel		25° ±1° CW/CCW
POWER INPUT		
Operating Voltage		12 or 24 V DC
Normal Operating Current		3.0 A @ 12 V DC 1.5 A @ 24 V DC
Maximum Current Continuously Rated		8.0 A @ 12 V DC 4.0 A @ 24 V DC
ENVIRONMENT		
Operating Temperature Range		-65 to +200 °F [-54 to +95 °C]
Relative Humidity		up to 100 %
All Surface Finishes		Fungus Proof and Corrosion Resistant
PHYSICAL		
Dimensions		See Section 4, Installation
Weight		8.25 lb [3.75 kg]
Mounting		Any Position, electrical connector at the top preferred
RELIABILITY		
Vibration Testing		Up to 20 g, 50 - 500 Hz 100 % Tested

[ES1080 Rev A 3-2025]

### 3 SELECTING THE 225 SERIES ACTUATOR

Select your actuator based on the following differentiators. GAC offers many similar products not shown on this list. Please contact GAC@governors-america.com for help selecting the best actuator for your needs.

PRODUCT	SYSTEM VOLTAGE		CONNECTOR			SAND-CAST*	HIGH TEMP	RETURN SPRING**		INCREASED TRAVEL	POSITION FEEDBACK SENSOR
	12	24	MIL	Commercial	Packard			Lesser	Greater		
ACB225											
ADB225											
ADB225G											
ADC225S-12											
ADC225S-24											
ADC225GS-12											
ADC225GS-24											
ADC225GAS-12											
ADC225GAS-24											
ADC225JS-12											
ADC225JS-24											
ADC225KS-24											
ADD225S-12											
ADD225S-24											
ADD225GSC-24											

\* All other 225 Series use diecast housing.

\*\* See p 6, [Actuator Spring Options](#) for details.

For recommended speed control units contact your GAC representative at GAC@governors-america.com  
Installation brackets and wiring needs are also available.

### CONNECTORS AND WIRING HARNESES

PRODUCT PREFIX	CONNECTOR PN	CONNECTOR DESCRIPTION
ACB/ADB	EC1000	Military Style Mating Connector Kit / Straight / 6 Terminals
ACB/ADB	EC1010	Military Style Mating Connector Kit / 90° / 6 Terminals
ADD	EC1300	Packard - Mating Connector Kit

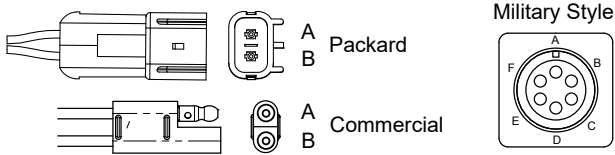

PRODUCT PREFIX	HARNESS PN	HARNESS DESCRIPTION
ACB/ADB	CH1203	Military Style 12 ft. (3.6m) Harness with Straight EC1000 / 6 Terminal Connector
ACB/ADB	CH1210	Military Style 12 ft. (3.6m) Harness with 90° EC1010 Connector / 6 Terminals
ADC	CH1206	Commercial 2 Terminal Connector on 4 ft. (1.2m) Harness
ADC	CH251-2134	Commercial 2 Terminal Connector on 7 ft. (2.13m) Harness - <u>Included with Actuator</u>
ADD	CH1215	Packard 2 Terminal Connector EC1300 on 6 ft. (1.8m) Harness



## 4 INSTALLATION

Mount the actuator taking into account the following:

- The electrical connector should be mounted facing the top.
- The actuator must be rigidly mounted as close as possible to the fuel control lever of the engine. Vibration will not affect the operation of the actuator.
- Take the following dimensions into account.

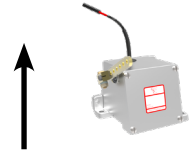

### ADC, ADD, and ADB DIMENSIONS

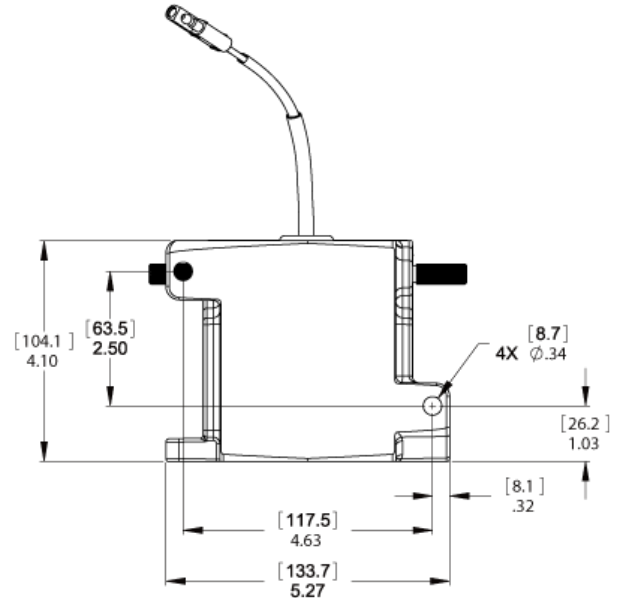
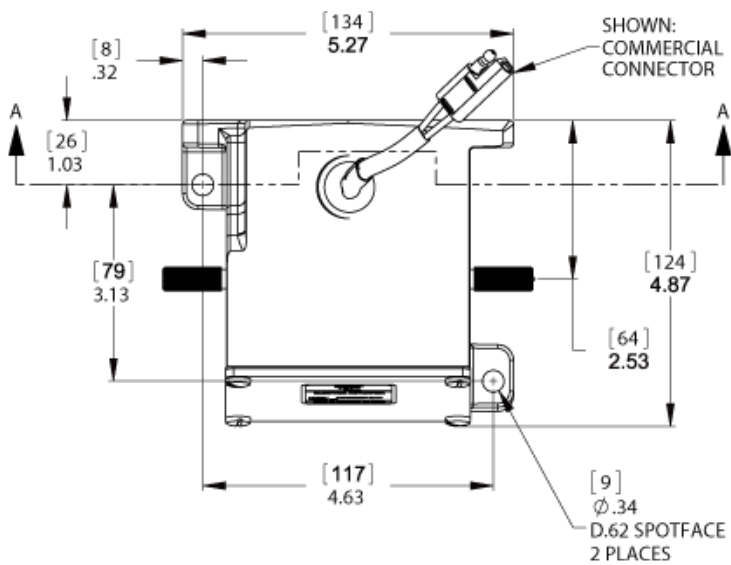

Dimensions: [mm]  
in

### ACB DIMENSIONS

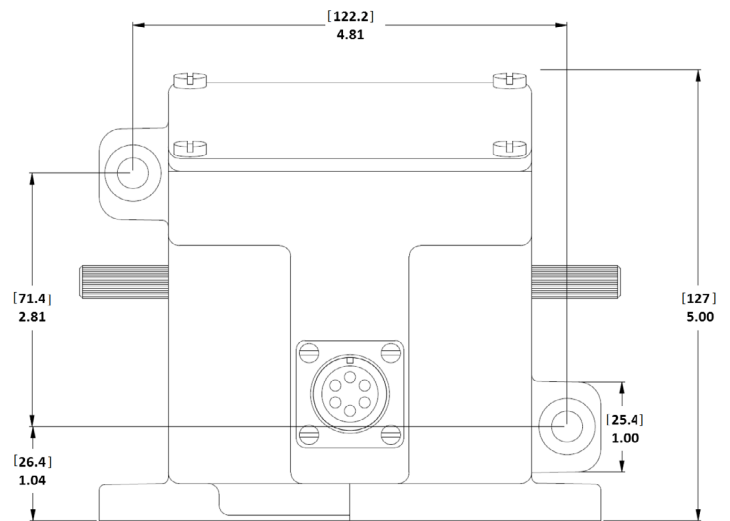
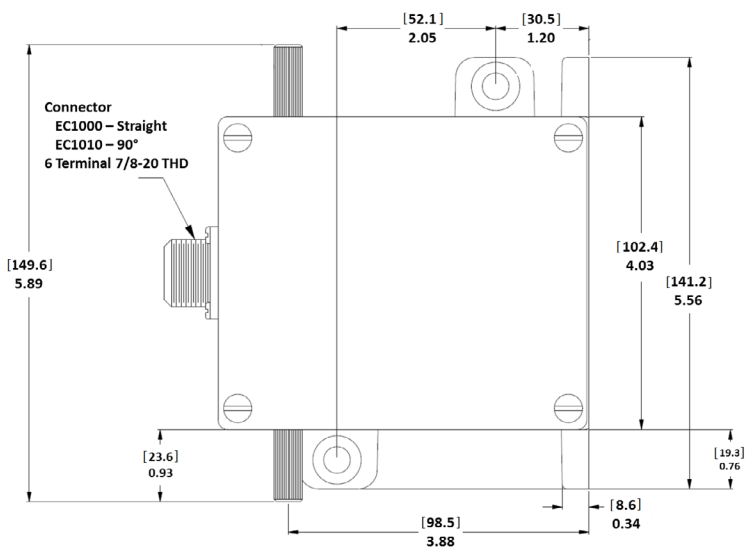

Dimensions: [mm]  
in

## 4 INSTALLATION (CONTINUED)

### LINKAGE

#### NOTE

Use high quality rod end bearings. Rod end bearings that have high friction can cause instability and require servicing. Levers and linkage should be sturdy yet low in mass for the fastest response.

The arrangement of the linkage for actuation of engine fuel control is an important application consideration.

For proportional actuators to operate with linear control systems there must be a linear relationship between actuator stroke and fuel delivery. Linear control systems, commonly diesel fuel systems, should set the linkage lever on the actuator nearly parallel to the pump lever at the mid fuel position for linear fuel control as shown in the FUEL LEVER AT MID FUEL POSITION diagram below.

For proportional actuators to operate with non-linear systems, must create a non-linear relationship between actuator stroke and fuel delivery. Carbureted, PT Pumps (CUMMINS), or other non-linear fuel systems require a non-linear fuel linkage configuration as shown in FUEL LEVER AT FULL FUEL POSITION diagram below. A non-linear fuel system results when more engine power is developed for a given stroke at positions of low fuel settings rather than at high fuel settings. In this case the levers should be parallel at full load.

Adjust the linkage so that the fuel control lever minimum and maximum fuel stops are used rather than the actuator internal mechanical stops. The actuator should be adjusted so that it operates over at least one half (12 degrees) of its available travel.

**FUEL LEVER AT MID FUEL POSITION**

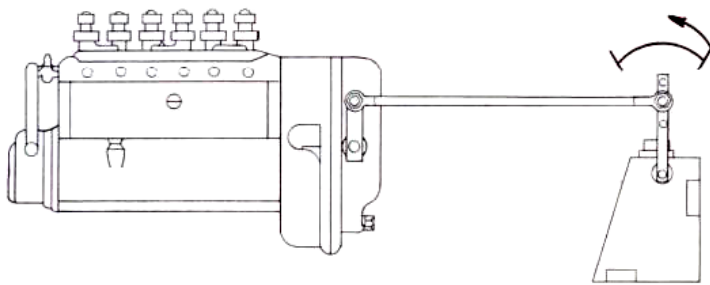

**FUEL LEVER AT FULL FUEL POSITION**

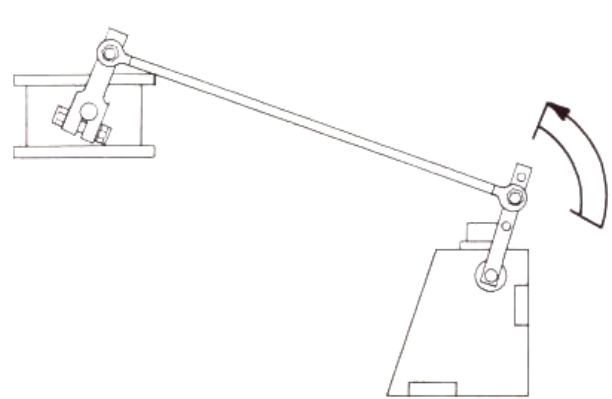

## 5 WIRING

The mating electrical connector must be wired in a configuration dependent on the system voltage supply. The maximum wire size that will fit into the actuator mating half connector is 16 AWG (1.3 mm<sup>2</sup>).

GAC's CH1203 is a pre-wired actuator cable harness 12 ft (4 m) in length and suitable for use on 12 or 24 volt systems. Other options are available from GAC as detailed in Section 3, Selecting the 225 Series Actuator.

PRODUCT PREFIX	VOLTAGE		MULTI-V DC	CONNECTOR
	12	24		
ACB				Military Style
ADB				
ADC				Packard / Commercial
ADD				

#### NOTE

Use larger gauge wire for cables longer than 10 ft (3 m) to reduce current losses and maintain full rotation of the actuator. Twisted and shielded actuator cable is recommended for EMI concerns.

**WIRING MULTI VOLTAGE MILITARY STYLE CONNECTOR UNITS**

**12 VOLT APPLICATIONS**

It is preferable to connect four wires, one to each of the coils and wire as shown in 12 VOLT OPERATION diagram.

Maximum current is 8 A. The recommended wire size is at least 16 AWG (1.3 mm<sup>2</sup>).

**12 VOLT OPERATION**

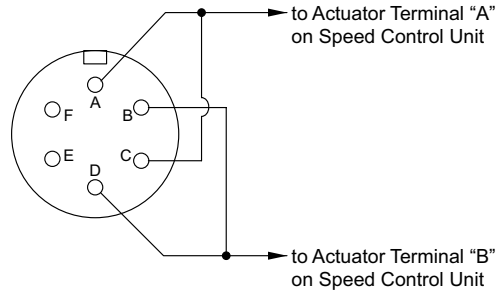

**24 VOLT APPLICATIONS**

A simple jumper wire between pins B and C at the mating half connector can be made.

The remaining two pins, A and D, can be extended to the required length.

Maximum current is 4 A. The recommended wire size is at least 18 AWG (1.0 mm<sup>2</sup>).

**24 VOLT OPERATION**

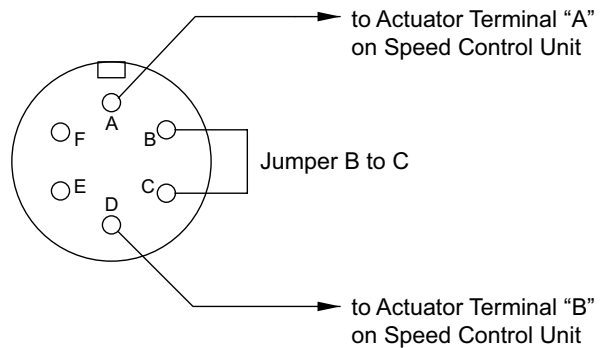

**ADB225F WIRING**

This version of the actuator includes a position sensor.

A GAC speed control unit that includes fuel management electronics is required to interface with this sensor. See the appropriate speed control unit literature for complete wiring information.

**ADB225F WIRING**

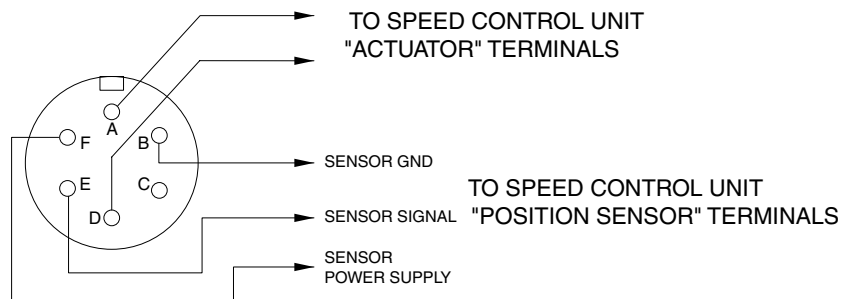

## 6 ADJUSTMENTS

Before starting the engine, make the following adjustments:

- Reconfirm that the linkage is not binding and that friction is minimal.
- Before starting the engine, push the actuator to the full fuel position and release. It should return instantly to the no fuel position without any binding.
- Once the engine has been started, the linkage can be optimized by temporarily inserting an ammeter in one of the wires between the speed control unit and the actuator or by measuring the voltage across the actuator.
- Measure the actuator current or voltage at no load and full load. The range and the starting current or voltage are important for optimizing the linkage system. Typical values are shown in the following table for 12 volt and 24 volt actuators.

ACTUATOR CURRENT/VOLTAGE RANGE CHART		
	12 VOLTS	24 VOLTS
No Load	2.5 Amp, 4 Volts	0.5 Amps, 12 Volts
Full Load	4 Amp, 6 Volts	1.2 Amps, 18 Volts

### INCREASE VOLTAGE RANGE

To increase the range of the actuator voltage or current, move the linkage to a lower hole on the actuator lever. A lower range of actuator current than suggested can cause instability or poor performance.

To increase or decrease the no load current or voltage, adjust the length of the link between the actuator and the engine fuel control.

#### NOTE

Smaller angles of actuator travel may improve transient performance, but will reduce available force at the fuel control lever. Allowing the actuator to operate through at least one half (12 degrees) of its stroke will usually provide near optimum response.

### ACTUATOR SPRING RATES ADJUSTMENT

Actuator spring rates provide an additional parameter to adjust for optimum governor stability and response.

ACTUATOR MODEL	SPRING PART NUMBER	SPRING RATE LBS / INCH	NOMINAL PRELOAD - LBS.
ADD225S ADC225S ADB225KS ADB225 ACB225	SP202	9.8	4.0
ADC225GS ADC225GAS ADD225GSC	SP203	4.7	4.6
ADC225JS	SP207	22.0	4.0
ADC225D1S (FIRE PUMP)	SP202 SP152	9.8 3.0	6.0
ADC225HS	SP101	4.6	2.7

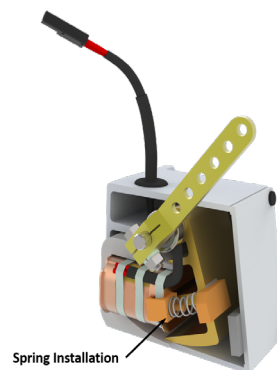
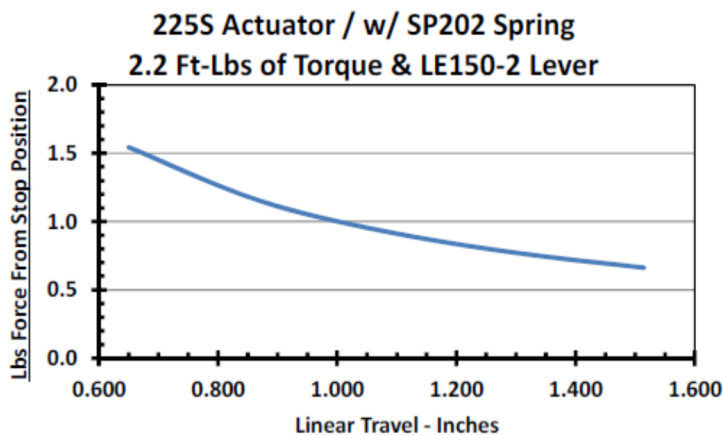

# 7

## TROUBLESHOOTING

If the governor system fails to operate, make the following tests at the actuator mounted connector while moving the actuator through its stroke.

### MEASURING RESISTANCE

Energize the actuator to full fuel (follow steps in your speed control unit publication) and manually move the actuator through its full range. No binding or sticking should occur. If the actuator passes the tests, the problem is elsewhere in the system. See your speed control unit troubleshooting publication as needed.

ADB225	
TERMINALS	RESISTANCE
A to B	2.5 $\Omega$
C to D	2.5 $\Omega$
A to C	$\infty$
A to Housing	$\infty$
C to Housing	$\infty$

ADC225 & ADD225	
TERMINALS	RESISTANCE
Red to White (12 V)	1.25 $\Omega$
Red to White (24 V)	5.0 $\Omega$
Red to Housing	$\infty$
White to Housing	$\infty$