

## 1 INTRODUCTION

The ESD5500E Series Speed Control Unit is an all-electronic device designed to control engine speed quickly and precisely in response to transient load changes.

The ESD5500E controls a wide variety of engines in isochronous or droop mode when connected to a proportional electric actuator and magnetic speed sensor. The ruggedly built ESD5500E series is designed to withstand the engine environment. Light-Force variations are available.

MODEL	DESCRIPTION
ESD5500E	Multi-V DC / Standard Unit
ESD5520E	Multi-V DC / Light-Force (Low-Current Optimized PID) / Enhanced Droop
ESD5522E	Multi-V DC / Light-Force (Low-Current Optimized PID) / Enhanced Droop for Cummins EFC Forward Acting (Normally Closed)
ESD5526E	Multi-V DC / Light-Force (Low-Current Optimized PID) / Anti-Windup Circuit (Gaseous) / Recommended for T1/T2 ATBs
ESD5528E	Multi-V DC / Anti-Windup Circuit (Gaseous)



## 2 SPECIFICATIONS

PERFORMANCE	
Isochronous Operation	± 0.25 % or better
Speed Range / Governor	1 - 7.5 kHz Continuous
Speed Drift with Temperature	±1 % MAX
Idle Adjust Clockwise	60 % of Set Speed
Idle Adjust Counterclockwise	Less than 1200 Hz
Droop Range	1 - 5 % regulation
Droop Adjust Maximum (K-L jumpered)	400 Hz ±75 Hz per 1.0 A change
Droop Adjust Minimum (K-L jumpered)	15 Hz ±75 Hz per 1.0 A change
Speed Trim Range	± 200 Hz
Remote Variable Speed Range	500 - 7.5 kHz
Terminal Sensitivity	
J	100 Hz ±15 Hz/Volt @ 5.0 kΩ Impedance
L	735 Hz ±60 Hz/Volt @ 65.0 kΩ Impedance
N	148 Hz ±10 Hz/Volt @ 1 MΩ Impedance
P	10 V DC Supply @ 20 mA MAX
INPUT / OUTPUT	
DC Supply	12 V DC and 24 V DC Battery Systems Transient and Reverse Voltage Protected*
Polarity	Negative Ground (Case Isolated)
Power Consumption	50 mA continuous plus actuator current
Speed Signal Range	1.0 - 50 V AC
Speed Sensor Signal	1.0 - 120 V RMS
Actuator Current Range** (77°F (25°C))	Minimum 1.0 A Nominal 7.0 A Peak 10.0 A

RELIABILITY	
Vibration	1 g @ 20-100 Hz
Testing	100 % Functionally Tested
ENVIRONMENTAL	
Ambient Temperature	-40° to 85 °C [-40° to 180 °F]
Relative Humidity	up to 95 %
All Surface Finishes	Fungus Proof, Corrosion Resistant
COMPLIANCE / STANDARDS	
Agency	CE (EN55011, EN50081-2, EN50082-2), RoHS, Lloyds Register, DNV/GL, Bureau Veritas
PHYSICAL	
Dimension	See Wiring Diagram and Outline
Weight	1.20 lb [0.54 kg]
Mounting	Any position, vertical preferred
[ES1075 3-2025 REV A]	

\* Protected against short circuit to actuator (shuts off current to actuator), unit automatically turns on when short is removed.

\*\* Protected against reverse voltage by a series diode. A 15 A fuse must be installed in the positive battery lead.

### 3 INSTALLATION AND OUTLINE DIAGRAM

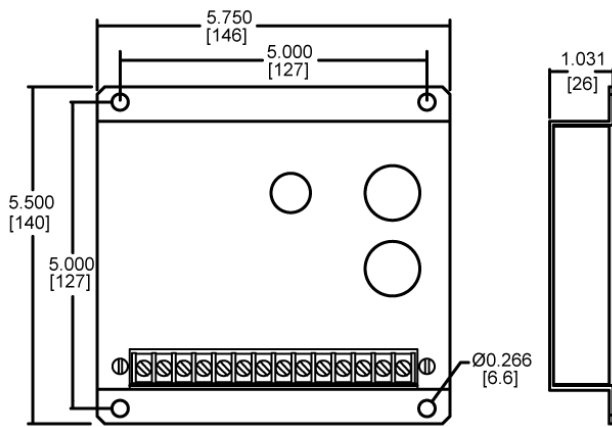

**READ THIS ENTIRE GUIDE BEFORE PERFORMING AN INSTALLATION.**

Vertical orientation allows fluids to drain in moist environments.



Avoid Extreme Heat



Mount in a cabinet, engine enclosure, or sealed metal box.



Dimensions in  
[mm]

### 4 ESD5500E WIRING



An overspeed shutdown device, independent of the governor system, must be provided to prevent loss of engine control which may cause personal injury or equipment damage. Do not rely exclusively on the governor system to prevent overspeed. A secondary shutoff device such as a fuel solenoid must be used.

**When wiring ESD5500E Series controllers:**

- 1. Use shielded cable for all external connections to the ESD controller.**
- One end of each shield, including the speed sensor shield, should be grounded to a single point on the ESD case.
- Terminal A, B, E, and F should be 16 AWG or larger. Long cables require increased wire size to minimize voltage drops.
- Battery positive (+) Terminal F should be fused for 15 A.
- Magnetic speed sensors Terminals C and D must be twisted and or shielded for the entire length.
- The gap between the speed sensor and the ring gear teeth should be smaller than 0.02 in [0.5 mm] usually backing out 3/4 turn after touching ring gear teeth. Speed sensor voltage should be at least 1 V AC RMS during cranking.
- If auto synchronization is used alone, not with a load sharing module, use a 3  $\Omega$  resistor between Terminal N and P to match the voltage between the speed control unit and the synchronizer.
- When operating at the upper end of the control unit frequency range, add a jumper wire between Terminal G and J to increase the frequency range of the control unit over 7000 Hz.
- Terminal P is used to supply +10 V DC regulated supply to accessories. No more than 20 mA of current can be drawn from this supply. Ground reference is Terminal G. A short circuit in this terminal can damage the speed control unit.
- 10. Do not over-tighten terminals.** Torque to no greater than 9.0 in-lb  $\pm 2.5$  [1.01  $\pm 0.28$  N·m].

# 4 ESD5500E WIRING CONTINUED

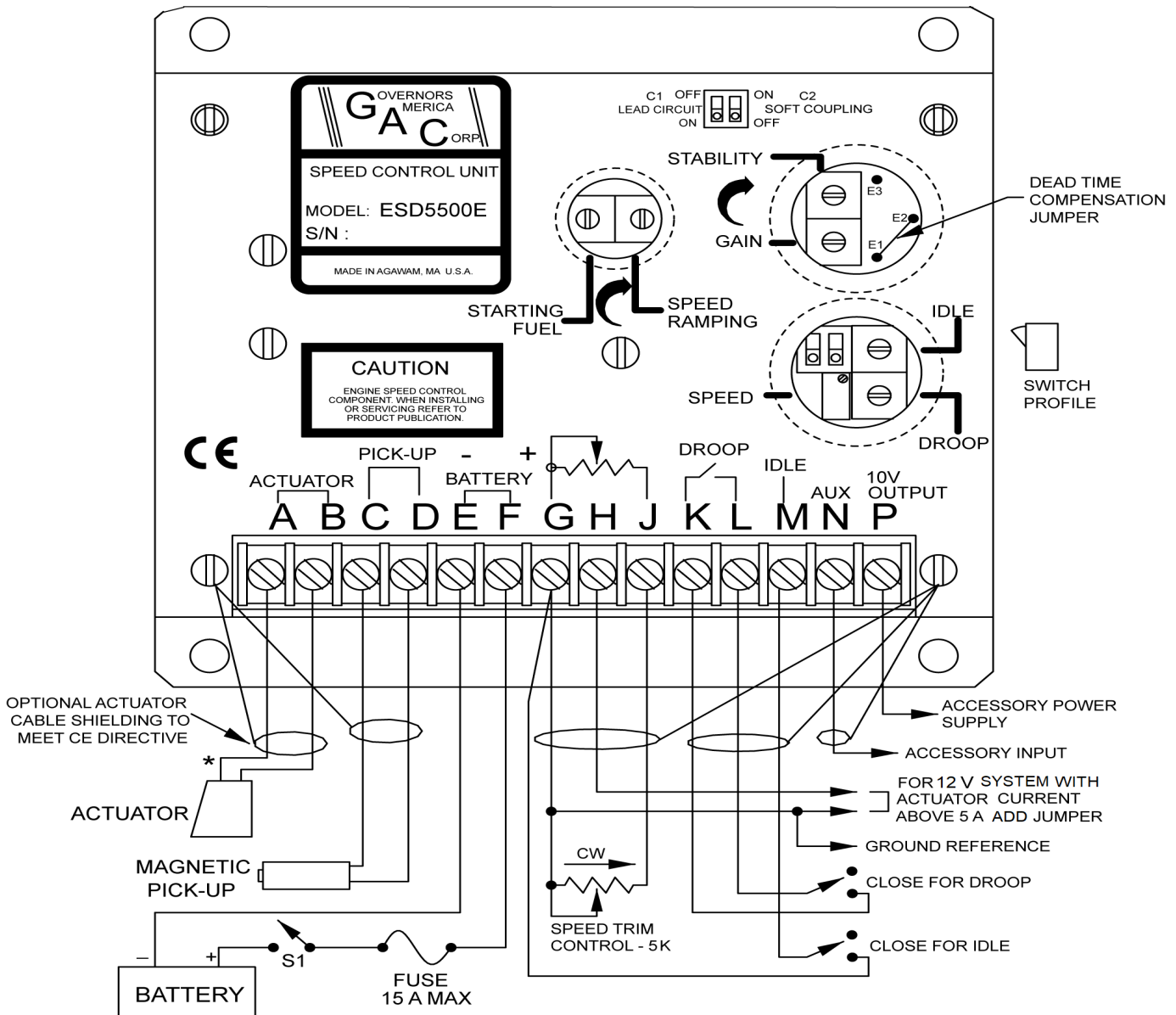

\*SEE SPECIFIC ACTUATOR PUBLICATION FOR WIRING DETAILS BASED ON BATTERY VOLTAGE

TERMINAL	DEFINITION	NOTES
A & B	Actuator (+/-)	16 AWG [1.3mm <sup>2</sup> ] or larger wire
C & D	Magnetic Speed Pickup (D is ground)	<ul style="list-style-type: none"> <li>Wires must be twisted and/or shielded for their entire length</li> <li>Gap between speed sensor and gear teeth should not be smaller than 0.02 in. (.51mm)</li> <li>Speed sensor voltage needs to be at least 1 V RMS during crank</li> </ul>
E & F	Battery Power (-/+)	<ul style="list-style-type: none"> <li>16 AWG [1.3mm<sup>2</sup>] or larger wire</li> <li>Install 15 A fuse in the Positive battery lead to protect against reverse voltage.</li> <li>Battery positive (+) input is Terminal F</li> </ul>
G	Ground Signal	
H	For 12 V systems with actuator currents above 5 A, may sometimes require a jumper between Terminals H and G	
J	Variable Speed	5 kΩ resistive nominal.
K & L	Droop Select	Active when closed
M	Idle Select	Close for Idle
N	Accessory Input	Load Sharing/Synchronizing, 0-10 V DC (5V Nominal, Reversed, 148 Hz/V). Shielded cabling recommended.
P	Accessory Power Supply	10 V DC Output To Power GAC Load Sharing and Synchronizing Modules

## 4 ESD5500E WIRING (CONTINUED)

### ADDING A POTENTIOMETER

Install a single remote speed adjustment **potentiometer** (speed trim control) to adjust engine speed. Select the desired speed range and the corresponding potentiometer value. If the exact range is not found select the next higher range potentiometer.

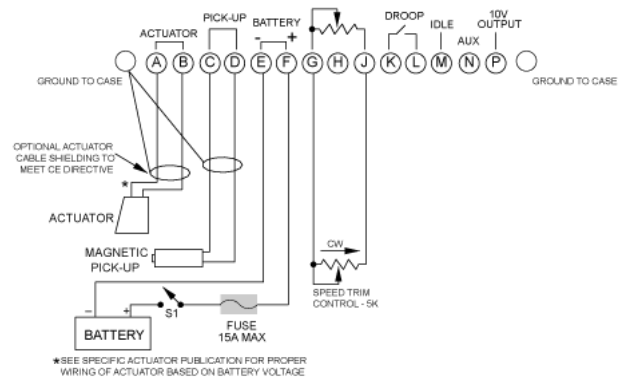
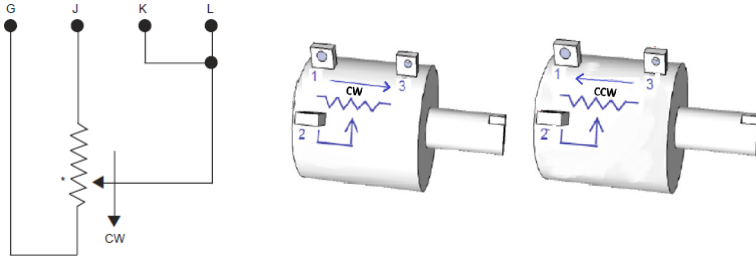

## 5 ADJUSTMENTS BEFORE ENGINE STARTUP

Make sure the following adjustments are set before starting the engine.

GAIN	Middle Position
STABILITY	Middle Position
SPEED TRIM CONTROL	Middle Position
STARTING FUEL	Full CW (MAX fuel)
SPEED RAMPING	Full CCW (fastest)

## 6 START THE ENGINE

The speed control unit governed speed setting is factory set at approximately engine idle speed. (1000 Hz., speed sensor signal or 600 RPM) If the engine does not start, adjust the speed potentiometer clockwise.

Crank the engine with DC power applied to the governor system. The actuator will energize to the maximum fuel position until the engine starts. The governor system should control the engine at a low idle speed. If the engine is unstable after starting, refer to [Section 8 ADJUSTING FOR STABILITY](#).

## 7 GOVERNOR SPEED SETTING

The governed speed set point is increased by clockwise rotation of the SPEED adjustment control. Remote speed adjustment can be obtained with an optional 5 kΩ Speed Trim Control **potentiometer**.

**IMPORTANT:**  
Speed Adjustment Is a 25  
Turn Potentiometer

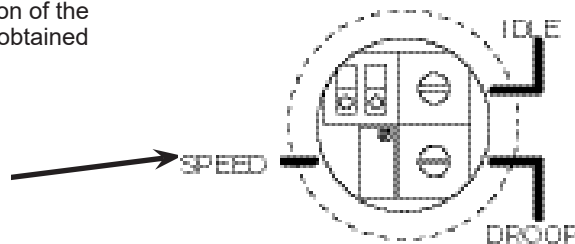

## 8 ADJUSTING FOR STABILITY

Once the engine is running at operating speed and at no load, the following governor performance adjustments can be made to increase engine stability.

**NOTE** Normally, adjustments made at no load achieve satisfactory performance. If further performance improvements are required, refer to Section 12 [TROUBLESHOOTING](#).

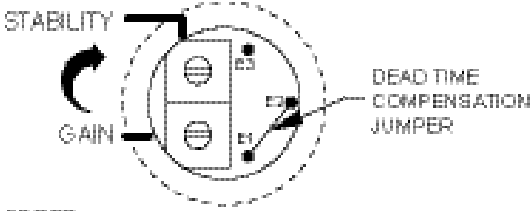

PARAMETER	PROCEDURE
GAIN	<ol style="list-style-type: none"> <li>1. Rotate the GAIN adjustment clockwise until instability develops.</li> <li>2. Gradually move the adjustment counterclockwise (CCW) until stability returns.</li> <li>3. Move the adjustment one division further counterclockwise to ensure stable performance (270° potentiometer).</li> <li>4. If instability persists, adjust the next parameter.</li> </ol>
STABILITY	Follow the same adjustment procedure, steps 1 - 3, as the GAIN parameter.

## 9 STARTING FUEL ADJUSTMENT

The engine's exhaust smoke at start-up can be minimized by completing the following adjustments:

1. Place the engine in idle by connecting Terminals M and G.
2. Adjust the IDLE speed for as low a speed setting as the application allows. Idle speed must be set for proper start fuel and speed ramping function, even if the idle feature is not used.
3. Adjust the STARTING FUEL CCW until the engine speed begins to fall. Increase the STARTING FUEL slightly so that the idle speed is returned to the desired level.
4. Stop the engine.

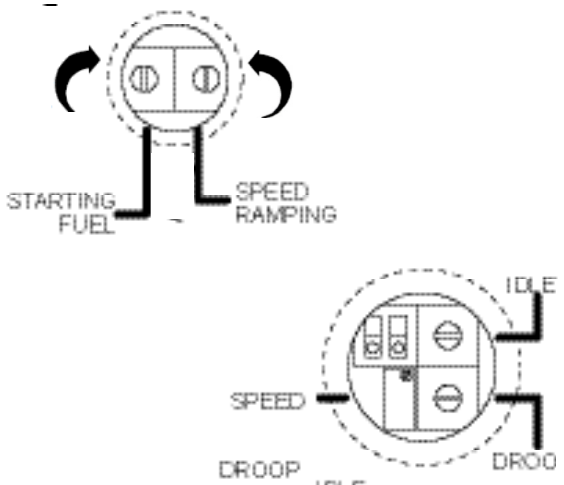

# 10 METHODS OF OPERATION

Select Operating Speed or Idle as your method of operation for the ESD5500E

## METHOD 1 - OPERATING SPEED

Start the engine and accelerate directly to the operating speed (Generator Sets, etc.).

### PROCEDURE

1. Remove the connection between Terminals M and G.
2. Start the engine and adjust the SPEED RAMPING for the least smoke on acceleration from idle to rated speed.
3. If the starting time is too long, the STARTING FUEL may need to be adjusted slightly clockwise (CW).

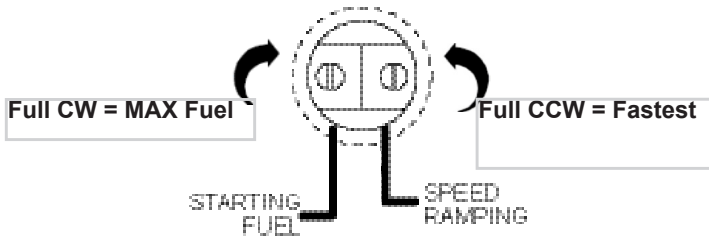

## METHOD 2 - IDLE SPEED

Start the engine and maintain at an idle speed for a period of time prior to accelerating to the operating speed. This method separates the starting process so that each may be optimized for the lowest smoke emissions.

### PROCEDURE

1. Replace the connection between Terminals M & G with a toggle switch or a normally open water jacket temperature switch. Other optical switch combinations can be used.
2. Start the engine.
3. If the starting smoke is excessive, the STARTING FUEL may need to be adjusted slightly CCW.
4. If the starting time is too long, the STARTING FUEL may need to be adjusted slightly CW.
5. When the switch opens, adjust the SPEED RAMPING for the least amount of smoke when accelerating from idle speed to rated speed.

## IDLE SPEED SETTING

If the IDLE speed setting was not adjusted as detailed in Section 9 Starting Fuel Adjustment, then place the optional external selector switch in the IDLE position.

The idle speed set point is increased by the clockwise rotation of the IDLE adjustment control. When the engine is at idle speed, the speed control unit applies droop to the governor system to ensure stable operation.

If not using the idle method, you can lower idle to the bare minimum (even if it's not being used) for smoke reduction.

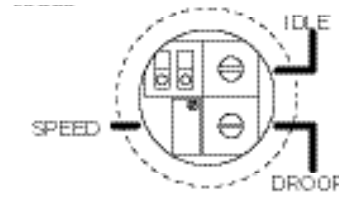

# 11 ADDITIONAL FEATURES AND OPTIONAL WIRING

## LEAD CIRCUIT & SOFT COUPLING

Switch 1(C1) controls the Lead Circuit. The normal position is ON. Move the switch to the OFF position if there is fast instability in the system.

Switch 2(C2) controls a circuit designed to eliminate fast erratic governor behavior, caused by very soft or worn couplings in the drive train between the engine and generator.

The normal position is OFF. Use the ON position if you experience fast erratic engine behavior between the engine and generator due to a soft coupling.

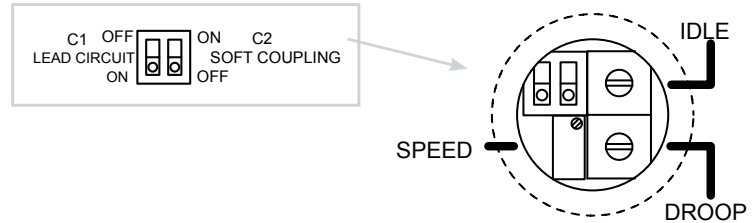

## ACCESSORY INPUT

The Auxiliary Terminal N accepts input signals from load sharing units, auto synchronizers, and other governor system accessories, GAC accessories are directly connected to this terminal.

**NOTE** Terminal N is sensitive (145 Hz/V). Accessory connections must be shielded.

When an accessory is connected to Terminal N, the speed will decrease and the speed adjustment must be reset.

If the auto synchronizer is used alone, not in conjunction with a load sharing module, a 3 Ω resistor should be connected between Terminals N and P. This is required to match the voltage levels between the speed control unit and the synchronizer.

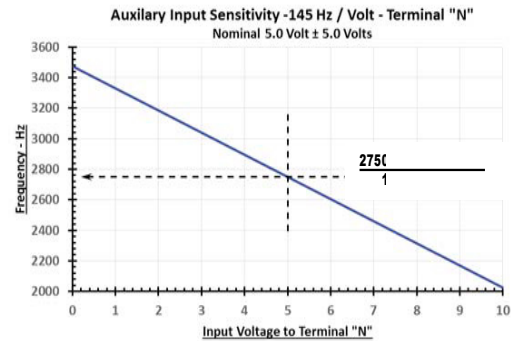

## ACCESSORY SUPPLY

The +10 volt regulated supply, Terminal P, can be utilized to provide power to GAC governor system accessories. Up to 20 mA of current can be drawn from this supply. Ground reference is Terminal G.



A short circuit on this terminal can damage the speed control unit. Do not connect Terminals N and P directly to each other.

# 11 ADDITIONAL FEATURES AND OPTIONAL WIRING (CONTINUED)

## REMOTE VARIABLE SPEED OPERATION

A single remote speed adjustment [potentiometer](#) is added to adjust the engine speed continuously over a specific speed range.

Select the desired speed range and corresponding potentiometer value (See [Variable Speed Table](#)). If the exact range cannot be found, select the next higher range potentiometer.

To maintain engine stability at the minimum speed setting, a small amount of droop can be added using the DROOP adjustment. At the maximum speed setting the governor performance will be near isochronous, regardless of the droop adjustment setting.

### NOTE

An additional fixed resistor may be placed across the potentiometer to obtain the exact desired range. Connect the speed range potentiometer using Terminals G and J. Contact GAC for assistance if you experience difficulty obtaining the desired variable speed governing performance.

VARIABLE SPEED TABLE	
SPEED FREQUENCY RANGE	POTENTIOMETER VALUE
900 Hz	1 kΩ
2400 Hz	5 kΩ
3000 Hz	10 kΩ
3500 Hz	25 kΩ
3700 Hz	50 kΩ

Potentiometer Wiring

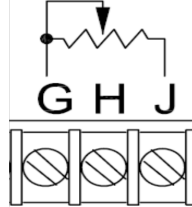

\*Select Proper Potentiometer

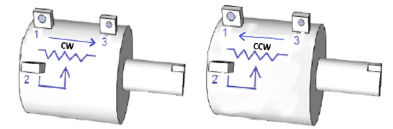

### Conversion Formulas

$$\text{Hertz}_{\text{MAG PICKUP}} = \frac{(\text{RPM} \times \#\text{Teeth})}{60} \quad \text{RPM} = \frac{(\text{Hertz}_{\text{MAG PICKUP}} \times 60)}{\#\text{Teeth}}$$

### NOTE

The ESD5500 series of controllers have the ability to expand the speed range by placing a jumper wire across terminals G and J. The standard range is 7400 Hz however this is based on the operating speed and the number of flywheel teeth (see formula). If your application is above this frequency, or near it – place the jumper and test again. This is an important step if your engine is not able to reach rated speed but the actuator is not saturated.

## SPEED DROOP OPERATION

Droop is typically used for the paralleling of engine driven generators. When in droop operation, the engine speed will decrease as engine load increases. The percentage of droop is based on the actuator current change from no engine load to full load.

Place the optional external selector switch in the DROOP position. DROOP is increased by clockwise rotation of the DROOP adjustment control.

After the droop level has been adjusted, the rated engine speed setting may need to be reset. Check the engines speed and adjust that speed setting accordingly.

### NOTE

Though a wide range of droop is available with the internal control, droop level requirements of 10% are unusual. If droop levels experienced are higher or lower than those required, contact [GAC for assistance](#).

# 12 TROUBLESHOOTING

If the engine governing system does not function, the fault may be determined by performing the voltage tests described in Steps 1 through 4. Positive (+) and negative (-) refer to meter polarity. Should normal values be indicated during troubleshooting steps, and then the fault may be with the actuator or the wiring to the actuator. Tests are performed with battery power on and the engine off, except where noted. See your actuator publication for actuator testing procedures.

## SYSTEM INOPERATIVE

STEP	WIRES	CHECK	PROBABLE CAUSE
1	F(+) & E(-)	Battery Supply Voltage (12 or 24 V DC)	<ol style="list-style-type: none"> <li>DC battery power not connected. Check for blown fuse.</li> <li>Low battery voltage</li> <li>Wiring error</li> </ol>
2	C(+) & D(-)	1.0 V AC RMS min. while cranking	<ol style="list-style-type: none"> <li>Gap between speed sensor and gear teeth too great. Check Gap.</li> <li>Improper or defective wiring to the speed sensor. Resistance between D and C should be 160 to 1200 <math>\Omega</math>. See your specific mag pickup data for resistance.</li> <li>Defective speed sensor</li> </ol>
3	P(+) & G(-)	10 V DC, Internal Supply	<ol style="list-style-type: none"> <li>Short on Terminal P</li> <li>Defective speed control unit</li> </ol>
4	F(+) & A(-)	1.0 - 2.0 V DC while cranking	<ol style="list-style-type: none"> <li>SPEED potentiometer set too low</li> <li>Short/open in actuator wiring</li> <li>Defective speed control</li> <li>Defective actuator, see your actuator manual for troubleshooting information.</li> </ol>

## INSUFFICIENT MAGNETIC SPEED SIGNAL

A strong magnetic speed sensor signal eliminates the possibility of missed or extra pulses. The speed control unit will govern well with 1.0 V RMS speed sensor signal. A speed sensor signal of 3 V AC or greater at governed speed is recommended. Measurement of the signal is made at Terminals C and D.

The amplitude of the speed sensor signal can be raised by reducing the gap between the speed sensor tip and the engine ring gear. The gap should not be any smaller than 0.02 in [0.5 mm]. When the engine is stopped, back the speed sensor out by 3/4 turn after touching the ring gear tooth to achieve a satisfactory air gap.

## INSTABILITY

INSTABILITY	CHECK	PROBABLE CAUSE
Fast Periodic	The engine seems to jitter with a 3 Hz or faster irregularity of speed.	<ol style="list-style-type: none"> <li>Make sure switch C1 is set to OFF.</li> <li>Readjust the GAIN and STABILITY for optimum control.</li> <li>Remove the E1 to E2 jumper. Readjust GAIN and Stability afterward.</li> <li>Turn off other electrical equipment that may be causing interference.</li> </ol>
Slow Periodic	An irregularity of speed below 3 Hz.	<ol style="list-style-type: none"> <li>Readjust the GAIN and STABILITY</li> <li>Adjust the DEAD TIME COMPENSATION by adding a capacitor from posts E2 to E3 (negative on E2). Start with 10 mF and increase until instability is eliminated.</li> </ol> <p>Check fuel system linkage during engine operation for:</p> <ul style="list-style-type: none"> <li>binding</li> <li>high friction</li> <li>poor linkage</li> </ul>
Non-Periodic	Erratic Engine Behavior	<p>Increasing the GAIN should reduce the instability but not totally correct it. If this is the case, there is most likely a problem with the engine itself. Check for:</p> <ul style="list-style-type: none"> <li>engine mis-firings</li> <li>erratic fuel system</li> <li>load changes on the generator set voltage regulator</li> </ul> <p>If throttle is slightly erratic, but performance is fast, move switch C1 to the OFF position.</p>

# 12 TROUBLESHOOTING (CONTINUED)

## UNSATISFACTORY PERFORMANCE

SYMPTOM	CHECK	PROBABLE CAUSE
Engine Overspeed	1. Do Not Crank. Apply DC power to the governor system.	<ol style="list-style-type: none"> <li>After the actuator goes to full fuel, disconnect the speed sensor at Terminal C and D. If the actuator is still at full fuel-speed then the speed control unit is defective.</li> <li>If the actuator is at minimum fuel position and there exists an erroneous position signal, then check speed sensor cable.</li> </ol>
	2. Manually hold the engine at the desired running speed. Measure the DC voltage between Terminals A(-) & F(+) on the speed control unit.	<p>If the voltage reading is 1.0 to 1.5 V DC:</p> <ul style="list-style-type: none"> <li>SPEED adjustment is set above desired speed</li> <li>Defective speed control unit</li> </ul> <p>If voltage reading is above 1.5 V DC then check for:</p> <ul style="list-style-type: none"> <li>actuator binding</li> <li>linkage binding</li> </ul> <p>If the voltage reading is below 0.8 V DC:</p> <ul style="list-style-type: none"> <li>Defective speed control unit</li> </ul>
Actuator does not energize fully	1. Measure the voltage at the battery while cranking.	<p>If the voltage is less than:</p> <ul style="list-style-type: none"> <li>7V for a 12V system, or</li> <li>14V for a 24V system, Then: Check or replace battery.</li> </ul>
	2. Momentarily connect Terminals A and F. The actuator should move to the full fuel position.	<ol style="list-style-type: none"> <li>Actuator or battery wiring in error</li> <li>Actuator or linkage binding</li> <li>Defective actuator</li> </ol>
	3. Measure frequency of magnetic speed pickup (or calculate).	If above 7000 Hz then add jumper to Terminal G and J.
Engine remains below desired governed speed	1. Measure the actuator output, Terminals A & B, while running under governor control.	<ol style="list-style-type: none"> <li>If voltage measurement is within 2 V DC of the battery supply voltage level, then fuel control is restricted from reaching full fuel position, possibly due to mechanical governor, carburetor spring, or linkage interference.</li> <li>SPEED parameter set too low</li> </ol>